

Instructions

HOC Extended features for chain drives.

230VAC

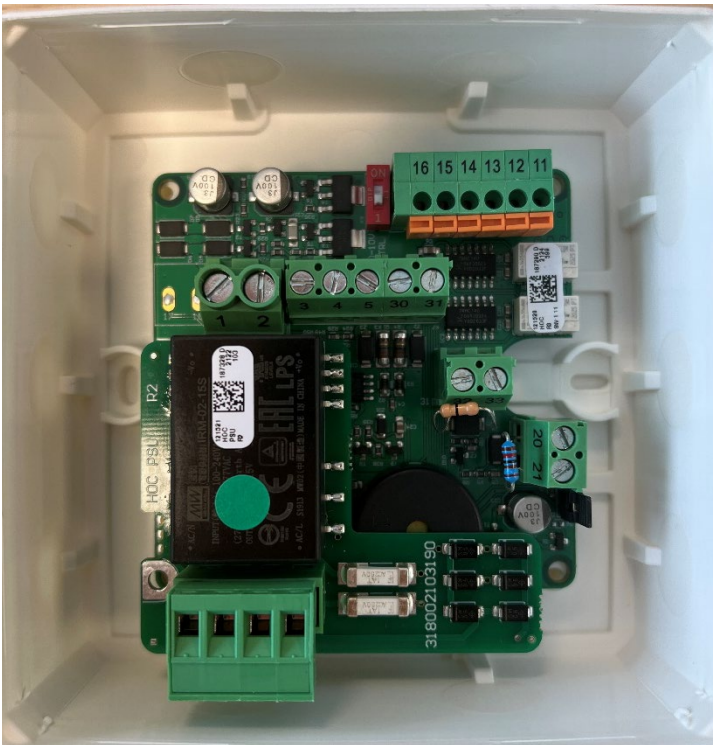

Safety Notes



- **Operating voltage 230VAC.**
- Connection must be carried out by authorized electricians.
- It's necessary to ensure that people keep away from the operation area of the drives. Danger of violent pressure in accessible area!

Application area

- For Open Close indication of chain motors
- Building Management System
- Anti-pinch protection
- Suitable for fire and heat ventilation

Features

- Microprocessor controlled BUS-communication
- White Plastic Housing
- Protective class: IP65
- Compatible to all Actulux chain drives third generation
- Compatible to all Actulux SV and SVM Control Panels
- Interface to MAYSER safety edge.
- Tested according to EN 12101-2, EN 50130-4.

Technical data

- Voltage: 230VAC \pm 15 %.
- Power Consumption: 30 mA
- Max Power in position relay 30VDC/2A
- Inrush current 10A
- Temperature range: -5°C ~ +55°C
- Protective class: IP65

LED	ON	Flashing
Safety edge active	Input below 400 ohms	Input above 2k ohm
Power	Module turned on	NA
Line error	NO communication to chain drive	NA
Buzzer beep	Error	NA

Dimensions of HOC box

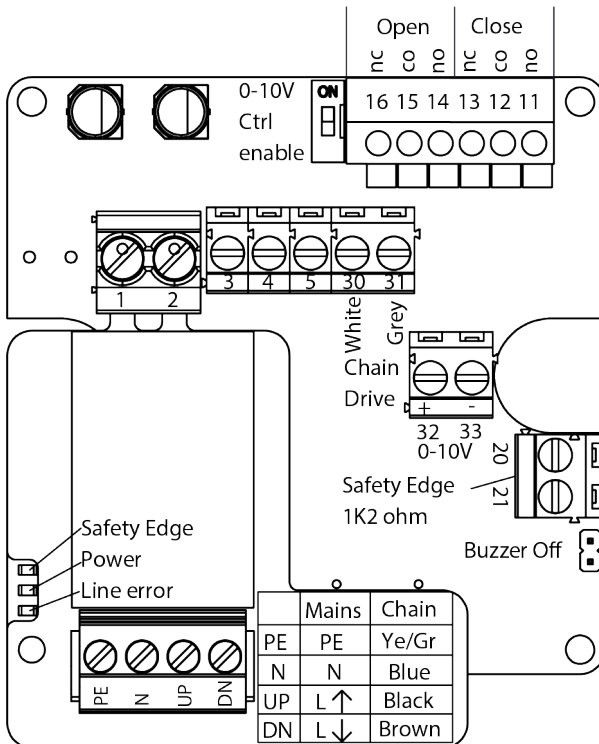
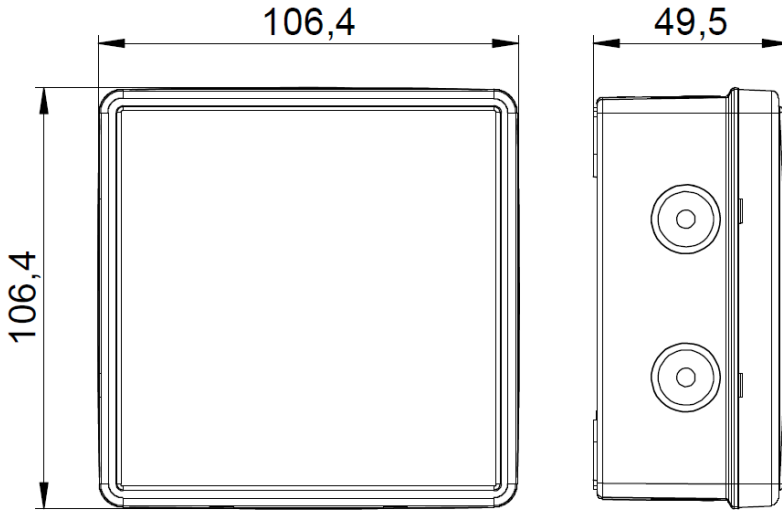

Connection of **HOC** and chain drive SVM control panel

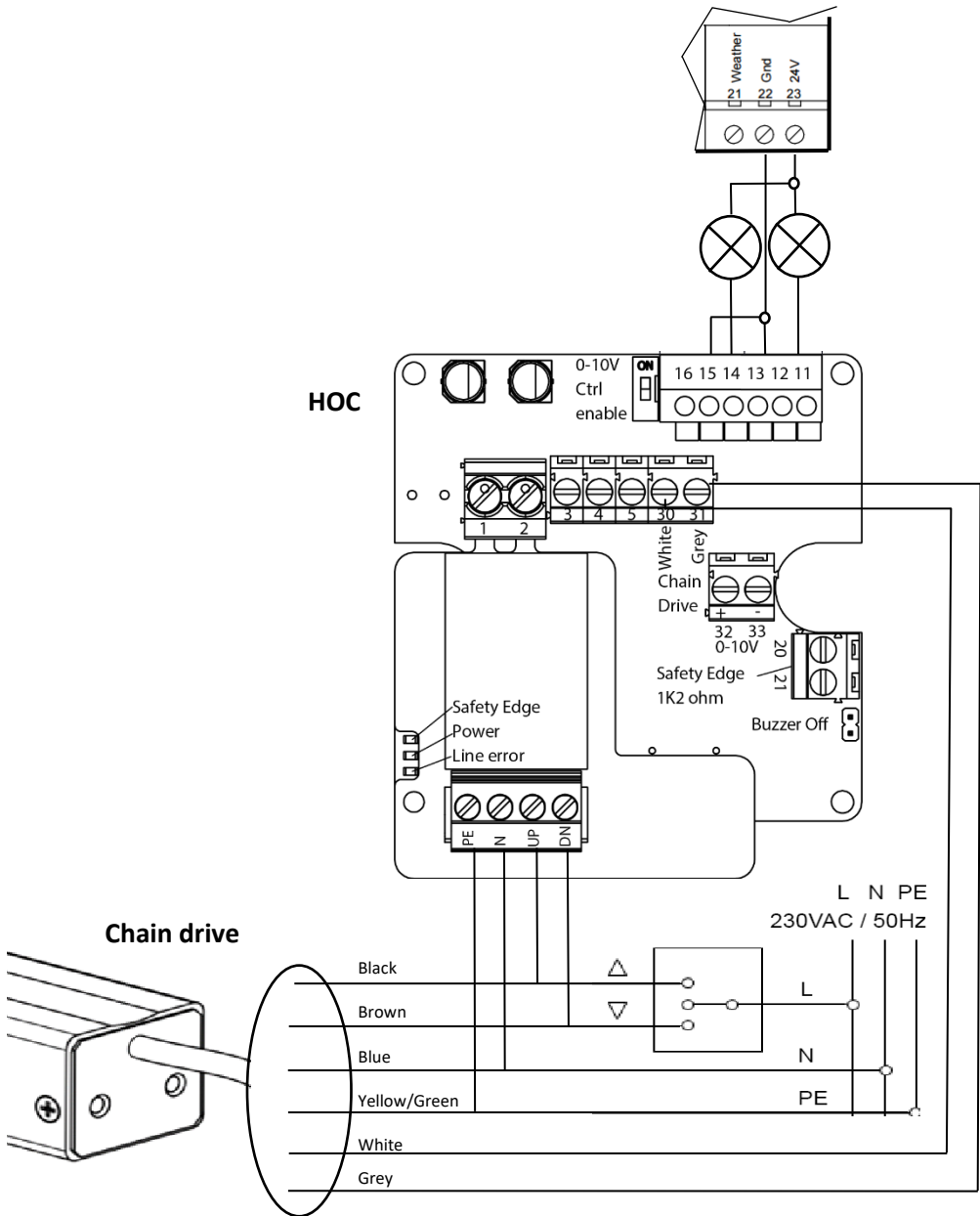

No further programming needed no matter chain length.
Up to 4 chain drives in synchro.

Safety edge installation

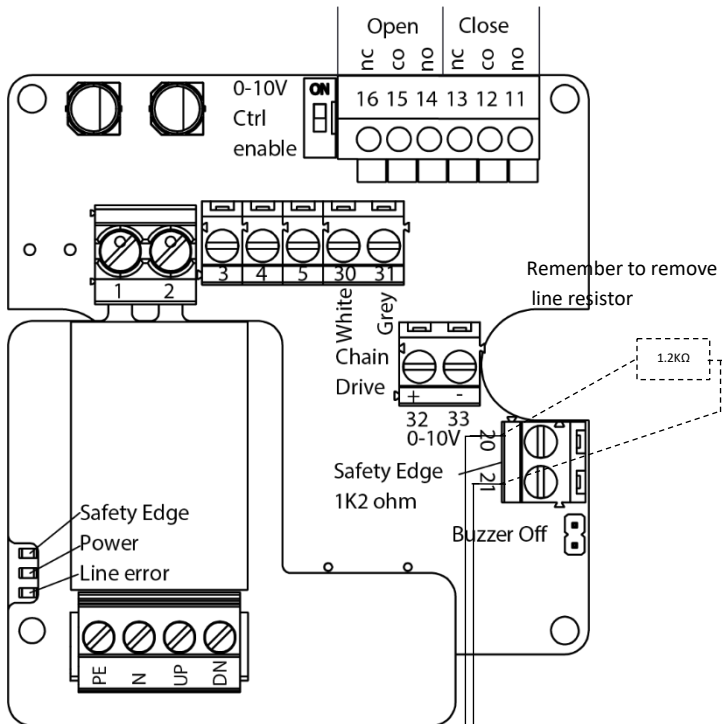

LED	ON	Flashing
Safety edge active	Input below 400 ohms	Input above 2k ohm
Power	Module turned on	NA
Line error	NO communication to chain drive	NA
Buzzer beep	Error	NA

Safety edge 1.2KΩ line resistor
E.G MAYSER

Remember to program Safety Edge Release distance in chain motor



Warranty

We refer to www.actulux.com

Disposal



Electrical equipment, accessories and packaging should be recycled for environment protection!

Don't dispose electrical equipment into household waste!

Only for EU-Countries: According to the European guideline 2002/96/EG about waste electrical and electronic equipment and its implementation into national law, useless electrical and electronic equipment must be separately collected and recycled for environment protection.

Contact

Actulux A/S

Porsborgparken 35

DK-9530 Stoevring

Denmark

Tel.: +45 98 57 40 90

www.actulux.com

©2017 Actulux A/S

Revision: A06 211827 – 11.01.2024

Rights to technical modifications reserved