

Electrical  
Systems

**Actulux**



## **Electrical Opening System - SA Roof Access**

maximum stability and minimum need of space

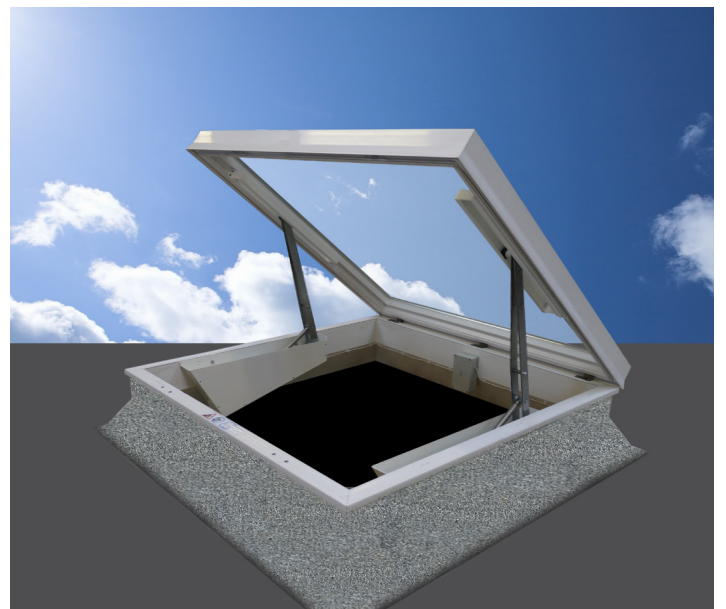



# Electrical Opening System - SA Roof Access

## FOR ROOF ACCESS

The opening system is developed for roof hatch & domes to make easy access to the roof.

## ELEGANT DESIGN AND COMPACT OPENING PRINCIPLE

The opening system has an elegant design. With its single and compact opening principle it demands a minimum of space, and possibility for pre-installation or retrofit on an existing hatch.

## MAXIMUM STABILITY AND POWER

The opening system is based on a unique geometric movement by means of an electrical actuator mounted in both sides of the upstand.

This system gives maximum stability and power exploitation both for opening and closing.

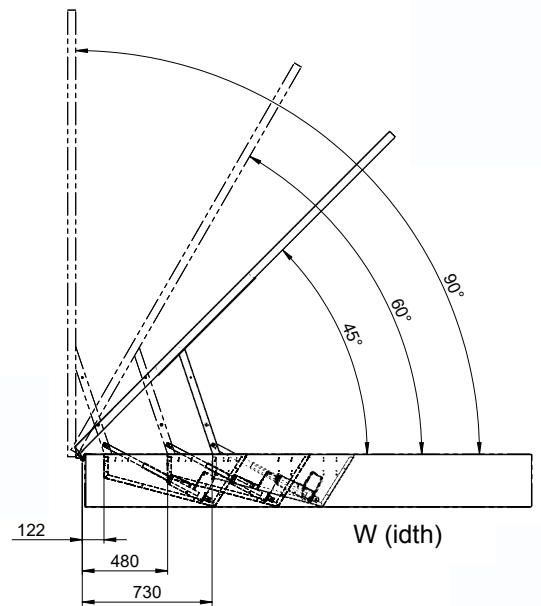

Model	Product no.	Power Supply	Cover size (W) examples	Opening angle	Maximum weight (at 140 cm width)	Temperature
SA Roof Access for 24V or 48V	222239	24V - 2x2.5A (5A) 48V - 2x1.25A (2.5A)	85 - 240 cm	45° - 90°	160 kg (210 kg)	-25°C - +55°C (+75°C)*
SA Roof Access for 230V	222223 222226	80W - 24V/2x1.5A (3A) 150W - 24V/2x3A (6A)			160 kg 210 kg	
SA Roof Access for 230V incl. remote control	222233 222236	80W - 24V/2x1.5A (3A) 150W - 24V/2x3A (6A)			160 kg 210 kg	

\*Requires special lubrication

## FEATURES

For roof access - painted in RAL 9016 WHITE

Very easy and flexible mounting

Opening angle: 45° to 90°

Extremely low noise level

Degree of protection: IP54                      Operation mode: S3 25% duty cycle

From motor unit: 200 cm (Max. cable length from motor to Lip control box overload unit)

Dimensions (l x h x w): 800 x 355 x 100 mm

Incl. overload protection

No maintenance required